



Hi-Rel HOLD-UP MODULE HUGD-300 : 300W POWER

Hi-Rel Grade ■■

Hold-Up Solution 9-45V & 16-80V DC/DC Converter Compatible Metallic Case

- 8 Vdc to 100 Vdc Input Voltage Range
- Compatible with 9 to 100Vdc modules
- Unique Product for Hold-Up Solution
- Reduce Capacitance by 80%
- Embedded Reverse Polarity Protection
- Power range : from 4W to 300W
- Compliant with MIL-HDBK-704-8
- Include monitoring signals
- Programmable hold up capacitor voltage
- RoHS process



1-General

The GAIA Converter Hold up device HUGD-300 provides a state-of-the-art solution to the problem of maintaining electronic system in operation during input bus drop-out. Usually this approach uses very large capacitors because they are only charged at the voltage at which power fails.

The Gaia Converter HUGD-300 module provides an alternative solution to reduce the amount of capacitance needed by charging the hold up capacitor at a high voltage value (adjustable from 31 to 80 VDC). It includes also a reverse polarity protection.

The HUGD-300 needs to be connected between the input line source bus and DC/DC modules. If an EMI filter and / or a pre-regulator is used, the HUGD-300 has to be connected between them and the converters.

Basically the HUGD-300 charges an external capacitor while powering the DC/DC converters. If the input voltage source bus drops out (power fail mode), the HUGD-300 generates a signal and allows the converters to be powered from the external capacitor.

The HUGD-300 can be used with any GAIA DC/DC converter since the capacitor voltage is externally adjustable from 31 to 80 VDC.

The HUGD-300 features 3 modes of operations:

- Charging operation mode : when the input voltage ramps-up and reaches the start-up charge threshold (which is set at the «power fail voltage» value), the HUGD-300 begins to charge the external capacitor while powering the dc/dc converter. The charging current is controlled as it is a constant power charger. When the capacitor voltage reaches 90% of it's final set value, the signal «capacitor charged» is activated and the HUGD-300 enters in the normal operation mode.

- Normal operation mode : in normal operation mode when the capacitor is charged and the input bus is between the «power fail» and 100VDC, the HUGD-300 only consumes low power to keep the capacitor charged. The HUGD-300 operates indefinitely in this state until the input voltage drops below the «power fail voltage» threshold.

- Power fail mode : when the input voltage drops below the «power fail voltage» threshold, a «power fail» signal is activated and the HUGD-300 disconnects input from output and connects the hold-up capacitor to the output. At this point the DC/DC converters are powered by the capacitor. When its voltage finally discharges to a value slightly above the «power fail voltage» threshold value, a «capacitor discharged» flag is activated.

2-Product Selection

HUGD - 300 -/ *option* - *suffix*

Options :

/T : option for -55°C start up operating temperature
/S : option for screening and serialization

Suffix :

nothing : RoHS process
-L : leaded process (available in N. America)

3- Block Diagram and Pin Description

The HUGD-300 module includes 3 main blocks :

- an input monitoring circuit
- an hold-up charger circuit
- a hold-up monitoring circuit

• **Input monitoring Circuit :**

The input monitoring circuit controls the value of the input bus voltage and compares it to the power fail threshold voltage (V_{th}) set externally through a resistor. Depending on this comparison, the circuit enables the activation of the hold-up switch or the hold-up charger and generates an open-drain «power fail flag (PF)».

• **Hold-up Charger :**

The hold-up charger is used to feed the hold-up capacitor with an adjustable constant voltage V_c from 31 Vdc up to 80 Vdc. The design of this charger limits the input inrush current as the charger is a constant power charger of 30W.

• **Hold-up monitoring Circuit :**

The hold-up monitoring circuit monitors the charging status of the hold-up capacitor.

The circuit generates 2 open-drain flags : the capacitor charged flag (CC) and the capacitor discharged flag (CD).

These flags can be used at system level for power interruption management (VME system, PCI, ...).

The following diagram represents the HUGD-300 series block diagram and pins.

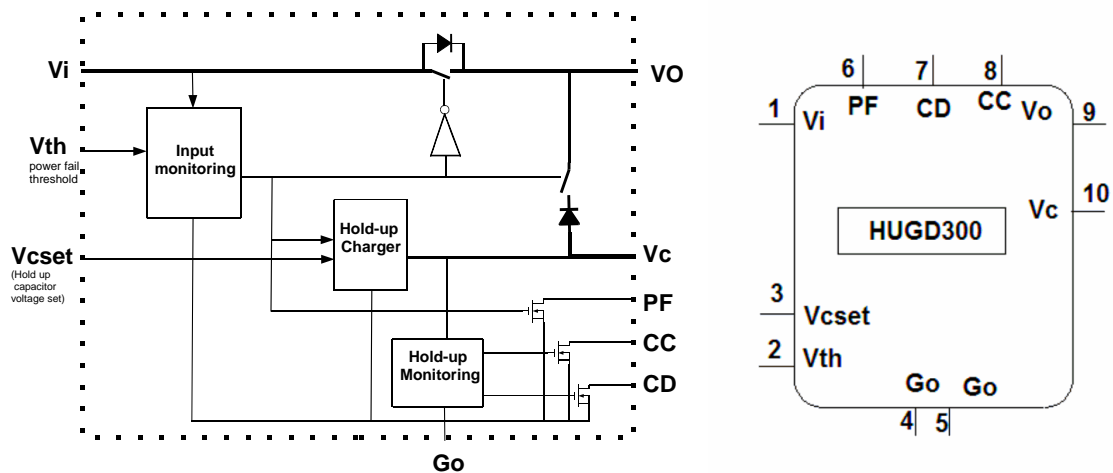

Pin Description :

Power Pin :

Vi : is the **+input** bus pin. Referenced to Go pin, it can accept a max permanent input voltage of 100V*, and can draw permanently 30A. Reverse voltage up to 100V applied to this pin will be stopped.

Go : common. It the ground that is used as reference for low signal electronics and charger. This common is not involved in power circuit high current.

Vo : Vout it is the output power lead. Since it can draw a maximum 30A current, and 100V voltage this pin is not protected against shortage to GO. It is protected against reverse polarity below -100 volt*. A transition capacitor must be connected to this pin see section 10 to avoid any transitory spike during hold-up operation.

Vc : is the holdup capacitor connection. It is mandatory to have it connected to a capacitor when Vcset is not grounded.

* see section 10

** contact factory for Vcmax=80 VDC

Control Pin :

Vcset : capacitor charge voltage setting. This pin is an input referenced to Go. The voltage on this pin is proportional to the final hold-up voltage (referred as Vcmax). The value of Vcmax range from 31 VDC to 70 VDC** and is set by a low power resistor across Vcset and Go. (see section 10)

Vth : this pin is an input referenced to Go. The voltage on this pin is proportional to the power fail threshold limit. The power fail threshold limit can be adjusted from 6V to 20V by connecting a low power resistor across Vth and Go.

Monitoring Pin :

PF : power fail signal is a flag active at low level that indicates the input voltage Vi has reached the value set by resistor across Vth and Go. It is an open drain topology that can draw 20mA max under 60V max.

CD : capacitor discharged signal is a flag that becomes active at low level when hold-up voltage has reached 120% of power fail voltage (PF voltage is set by resistor connected across Vth and Go). It is an open drain topology that can draw 20mA max under 60V max.

CC : capacitor charged signal is a flag that becomes active at low level when hold-up voltage has reached 90% of hold-up final voltage (set by resistor connected across Vcset and Go). It is an open drain topology that can draw 20mA max under 60V max.

4- Electrical Specifications

Data are valid at +25°C, unless otherwise specified.

Parameter	Conditions	Limit or typical	Units	HUGD-300
Input & Power				
Permanent input voltage range	Full temperature range Full load	Minimum	VDC	8
		Maximum	VDC	100*
Transient input voltage	Full temperature range Full load	Maximum	VDC/ms	/
Dissipated power in normal mode	Full temperature range	Maximum	W	3
Equivalent serie resistor in power line	Full temperature range	Typical	mOhm	7
Output power/current	Temperature Tcase 90°C	Maximum	W	300
			A	or 30
Charger				
Charger input voltage operation range	Full temperature range Full load	Minimum	VDC	9
		Maximum	VDC	100
Power fail voltage threshold (Vfail)	with the setting Vth connected to ground	Minimum	VDC	8
Power fail voltage threshold (Vfail)	with the setting Vth unconnected	Maximum	VDC	20
Set up charger start up level	Adjustable by power fail threshold	Minimum	VDC	9
		Maximum	VDC	20
Power consumption during holdup capacitance charge	Full temperature range Ui =9Vdc to 12Vdc Ui=12Vdc to Ui max.	Nominal	W	10
		Nominal	W	30
Admissible hold-up capacitor	/	Minimum	μF	470
		Maximum	μF	100 000
Adjustable hold-up capacitor final voltage	Adjustable by resistor on Vcset	Vcset connected to gnd	VDC	31
		Vcset adjusted (see §10)	VDC	70**
Control Signals				
Capacitor charged signal (CC) threshold : 90% of holdup capacitor final value	Turn off threshold Turn on threshold	Typical	VDC	open drain
		Typical	VDC	
Capacitor discharged signal (CD) threshold : 120% of power fail threshold	with setting Vth unconnected	Minimum	VDC	open drain
		Maximum	VDC	
CC, CD, PF sink current max. voltage	/	Maximum	mA	20
		Maximum	VDC	60
Hold-up time at 300W load ***	Vth unconnected Vth connected to ground	Minimum	μs/μF	10
		Minimum	μs/μF	10,7
Hold-up time at 10W load ***	Vth unconnected Vth connected to ground	Minimum	μs/μF	30
		Minimum	μs/μF	32

Note * : see section 10

Note ** : for hold-up capacitor final voltage up to 80 Vdc conslut factory

Note *** : for charging voltage from 8 Vdc to 80 Vdc

5- Switching Frequency

Characteristics	Conditions	Limit or typical	Performances
Switching frequency in boost mode	Charging capacitor	Nominal	1 MHz

6- Isolation

Parameter	Conditions	Limit or typical	Specifications
Electric strength test voltage	Input to output	/	No isolation
Electric strength test voltage	Input to case Output to case	/	500 VDC 500 VDC

4

7- Reliability Data

Characteristics	Conditions	Temperature	Specifications
Mean Time Between Failure (MTBF) According to MIL-HDBK-217F	Ground fixed (Gf)	Case at 40°C Case at 85°C	Consult factory
	Airborne, Inhabited, Cargo (AIC)	Case at 40°C Case at 85°C	Consult factory
Mean Time Between Failure (MTBF) According to IEC-62380-TR	Civilian avionics, calculators	Ambient at 55°C 100% time on	Consult factory

8- Thermal Characteristics

Characteristics	Conditions	Limit or typical	Performances
Operating ambient temperature range at full load	Ambient temperature *	Minimum Maximum	- 40°C + 90°C
Operating case temperature range at full load	Case temperature	Minimum Maximum	- 40°C +105°C
Storage temperature range	Non functioning	Minimum Maximum	- 55°C + 125°C
Thermal resistance	Rth case to ambient in free air natural convection	Typical	13°C /W

Note * : The upper temperature range depends on configuration, the user must assure a max. case temperature of + 105°C.

The HUGD-300 series operating **case** temperature must not exceed 105°C. The maximum **ambient** temperature admissible for the hold-up module corresponding to the maximum operating case temperature of 105°C depends on the ambient airflow, the mounting/orientation, the cooling features and the power dissipated.

To calculate a maximum admissible ambient temperature the following method can be used. Knowing the maximum case temperature Tcase = 105°C of the module, the input current Iin and the ESR (operating serie resistance) :

- determine the power dissipated by the module P_{diss} that should be evacuated :

$$P_{diss} = ESR \times I_{in}^2$$

- determine the maximum ambient temperature :

$$T_a = 105^\circ\text{C} - R_{th} \times P_{diss}$$

where **Rth** is the thermal resistance from the case to ambient.

The previous thermal calculation shows two areas of operation :

- a normal operation area in a free natural ambient convection (grey area in this following graph),
- an area with cooling features (air flow or heatsink) ensuring a maximum case temperature below the maximum operating case temperature of 105°C (white area in the following graph).

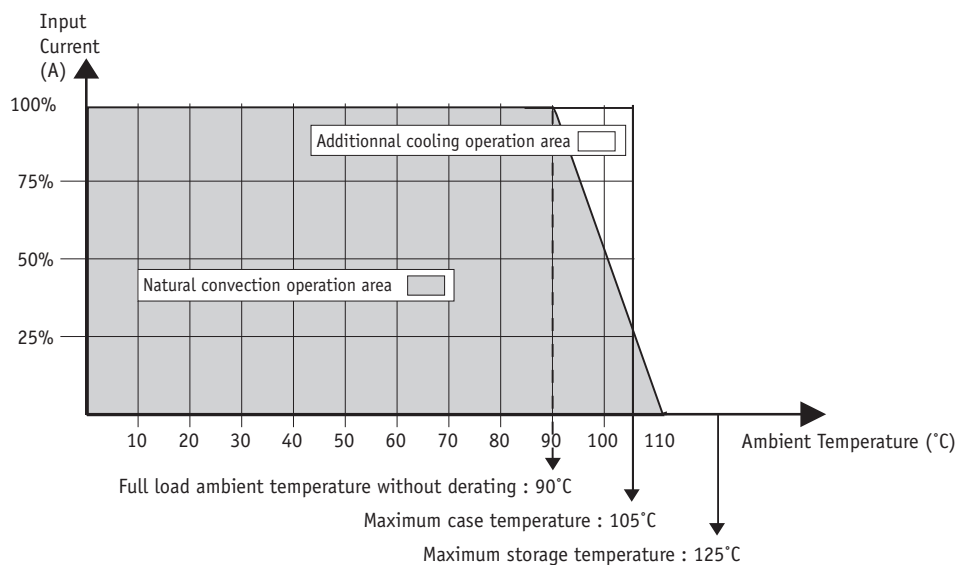



9- Environmental Qualifications

The modules have been subjected to the following environmental qualifications.

Characteristics	Conditions	Severity	Test procedure
Climatic Qualifications			
Life at high temperature	Duration Temperature / status of unit	Test D : 1 000 Hrs @ 105°C case, unit operating @ 125°C ambient, unit not operating	MIL-STD-202G Method 108A
Altitude	Altitude level C Duration Climb up Stabilization Status of unit	40 000 ft@-55°C 30 min. 1 000 ft/min to 70 000 ft@-55°C, 30 min. unit operating	MIL-STD-810E Method 500.3
Humidity cyclic	Number of cycle Cycle duration Relative humidity variation Temperature variation Status of unit	10 Cycle I : 24 Hrs 60 % to 88 % 31°C to 41°C unit not operating	MIL-STD-810E Method 507.3
Humidity steady	Damp heat Temperature Duration Status of unit	93 % relative humidity 40°C 56 days unit not operating	MIL-STD-202G Method 103B
Salt atmosphere	Temperature Concentration NaCl Duration Status of unit	35°C 5 % 48 Hrs unit not operating	MIL-STD-810E Method 509.3
Temperature cycling	Number of cycles Temperature change Transfer time Steady state time Status of unit	200 -40°C / +85°C 40 min. 20 min. unit operating	MIL-STD-202A Method 102A
Temperature shock	Number of shocks Temperature change Transfer time Steady state time Status of unit	100 -55°C / +105°C 10 sec. 20 min. unit not operating	MIL-STD-202G Method 107G
Mechanical Qualifications			
Vibration (Sinusoidal)	Number of cycles Frequency / amplitude Frequency / acceleration Duration Status of unit	10 cycles in each axis 10 to 60 Hz / 0.7 mm 60 to 2 000 Hz / 10 g 2h 30 min. per axis unit not operating	MIL-STD-810D Method 514.3
Shock (Half sinus)	Number of shocks Peak acceleration Duration Shock form Status of unit	3 shocks in each axis 100 g 6 ms 1/2 sinusoidal unit not operating	MIL-STD-810D Method 516.3
Bump (Half sinus)	Number of bumps Peak acceleration Duration Status of unit	2 000 Bumps in each axis 40 g 6 ms unit not operating	MIL-STD-810D Method 516.3

10- Application Notes

10-1 General on Input Bus Shut-Down Requirements

During bus power drop-out, avionics and military systems require a maintain of operation for data saving and shut-down control. The duration of this shut-down operation is defined in different standards and can last up to 7 secondes.

10-1-1 Capacitor Stand-Alone Solution

To maintain operation during power drop-out, the traditional approach is to use a bulk capacitor connected at the input of the converters to power them when power drops-out. This capacitor depends on the system specifications, the load, the efficiency of the DC/DC converter and the hold-up time requirement. The value of the capacitance is determined by the following formula :

$$C1 = \frac{2 \times P \times Dt}{h \times (V1^2 - V2^2)}$$

where :

- C : is the required capacitor (in farads)
- P : is the power at the load (output of converter)
- h : is the efficiency of the converter at rated load
- Dt : is the required hold up time (in seconds)
- V1 : is the initial charged capacitor voltage (in volts)
- V2 : is the low line voltage of DC/DC converter

For a typical 100ms hold-up time requirement with 200W output power, and a GAIA Converter module with a minimum permanent input voltage at 9V with 80% efficiency connected on a MIL-STD-704 28V bus that can range down to 22V, the resulting capacitor is a large $(2 \times 200 \times 0,1) / (0,8 \times (28^2 - 9^2)) = 72\ 150\ \mu\text{F}$ capacitance so a 82 000 $\mu\text{F}/40\text{V}$ bulk capacitor or even larger if we consider the initial voltage as the minimum permanent input bus voltage (i.e 22V).

Using stand alone capacitor conduct to face 2 main issues:

- 1) Voltage before interruption (V1) follows the input bus minimum steady state, reducing by the way the stored energy when bus is at its low value. In some case the Hold-up is not possible because $V1 < V2$.
- 2) Needed hold up capacitor value are so large than Inrush current at 1st step of charging need to be limited by a power resistor .

In consequence the typical schematic for stand alone capacitor value is as described below:

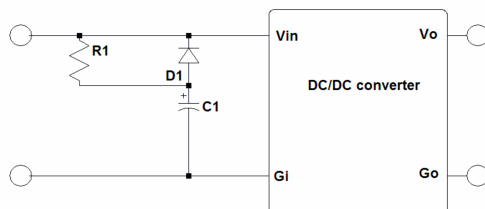

- R1 = Power resistor to limit inrush current
- D1 = Hold-up mode diode
- C1 = Hold-up capacitor

10-1-2 Capacitor with Hold Up Module Solution

To reduce drastically the size of this capacitor, GAIA Converter proposes the HUGD-300 hold-up module that will charge the capacitor at a higher voltage from 31V to 80VDC.

Moreover this module also allows to select the minimum threshold voltage at which the capacitance will power the converters. In this case the amount of capacitance needed for a given hold up time is determined by the following formula :

$$C2 = \frac{2 \times P \times (Dt + 0.01)}{h \times (Vcset^2 - V2^2)}$$

where :

- C : is the required capacitor (in farads)
- P : is the power to the load (output of converter) (in watts)
- h : is the efficiency of the converter at rated load
- Dt : is the required hold up time (in seconds)
- Vcset : is the capacitor charge voltage set from HUGD-300
- V2 : is the low line voltage of DC/DC converter (in volts).

4

For a typical 100ms hold-up time requirement with 200W output power, and a GAIA Converter module with a minimum permanent input voltage at 16VDC with 80% efficiency connected on a MIL-STD-704 28V bus, using the HUGD-300 set for a capacitor charge voltage of 70VDC will reduce the capacitanc value down to $(2 \times 200 \times 0,1) / (0,8 \times (70^2 - 16^2)) = 10\ 767\ \mu\text{F}$ so a typical 12.000 $\mu\text{F}/100\text{V}$ bulk capacitor.

The HUGD-300 takes the advantage of boosting hold-up cap voltage to enlarges the V1-V2 voltage difference whatever the input bus voltage before hold-up is.

The gain is not proportional to V2 but to $V2^2$ so stored energy is growing according to a quadratic curve. In addition HUGD-300 manages the inrush current without necessity of external power resistor.

10- Application Notes (continued)

10-2 Hold-up Capacitor Selection with HUGD-300 Solution

The external capacitor supplies the energy for the DC/DC converters operation during power drop-out. The capacitance should not exceed 100.000µF, and should be lower than 470µF. The amount of capacitance for a given hold up time is given by the formula :

$$C = \frac{2 \times P \times Dt}{V_{cset}^2 - V_L^2}$$

where

- C : is the required capacitance (in Farads)
- P : is the power consumed by the DC/DC converters (in Watts)
- Dt : is the required hold-up time (in seconds)
- Vcset : is the capacitor charge voltage set up
- V_L : is the lowest admissible voltage of DC/DC converters (in volts)

The following curves give the hold-up time (or transparency time) as a function of the capacitance value for 2 values of setting Vcset (45 VDC and 80 VDC) in conjunction with adapted GAIA Converter module families i.e 9-45 Vdc and 16-80 Vdc input range. Gaia Converter recommends low ESR extended temperature range electrolytic capacitor.

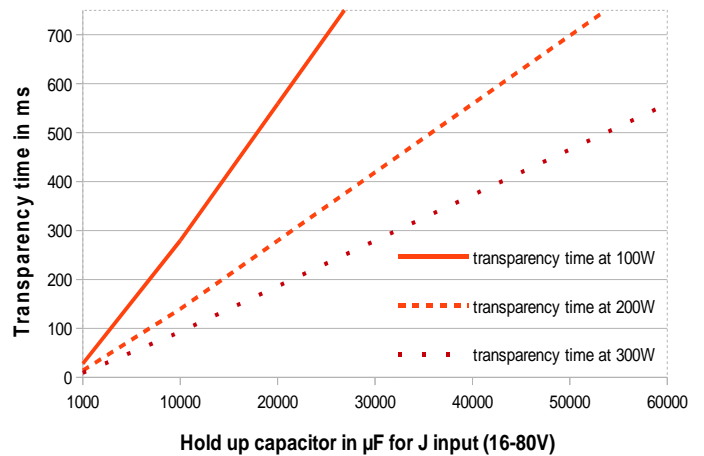
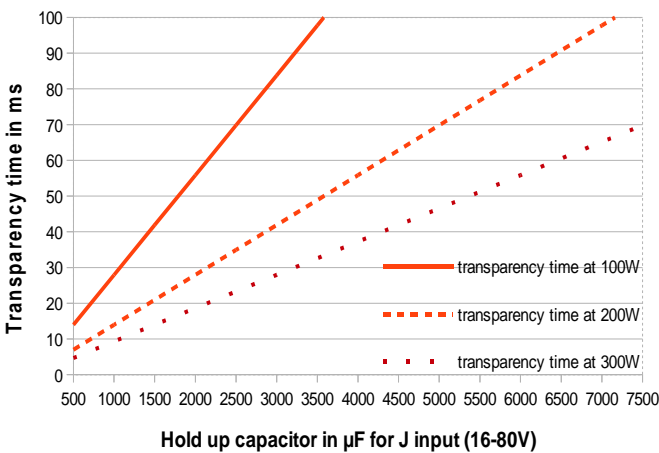
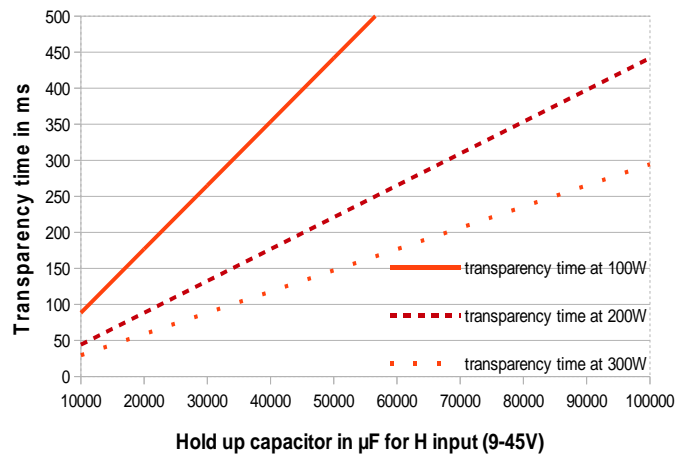
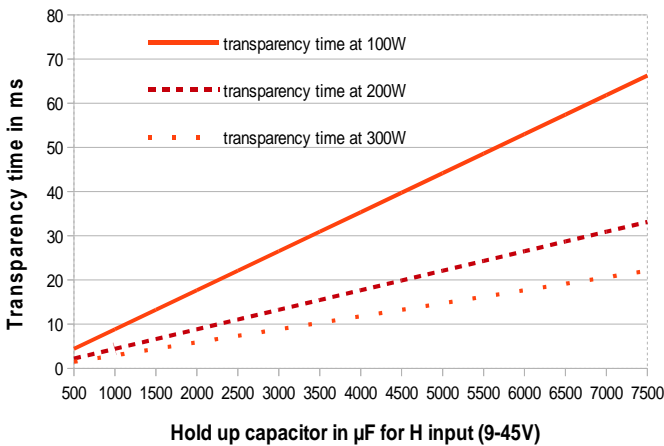

10- Application Notes (continued)

10-3 Power Fail Voltage Threshold : Vth

The «power fail voltage» threshold determines the operation mode of the HUGD-300.

This threshold has to be set up in conjunction with the type of modules used (i.e. 9-36/9-45 VDC, 10-100 VDC or 16-40/16-80 VDC input voltage type of modules) and can be adjusted between 6 VDC and 20 VDC by an external resistor Rth connected between the Vth pin and Gnd pin. Vth unconnected will set the threshold at 20 VDC whereas Vth connected to ground will set the threshold at 6 VDC. The following curve shows the Vth function threshold as a function of the resistor Rth.

The hysteresis on the undervoltage detection is typically 2 VDC. Once an undervoltage has been detected and the input bus has been disconnected to switch on the hold-up capacitor energy reservoir, the HUGD-300 will reconnect the input bus when it is 2 VDC above the value set with the Vth pin. Therefore, it is recommended to minimize the series resistance of elements in front of the HUGD-300 to prevent false triggerings when the input current becomes 0A as the Vth threshold is reached and the bus is disconnected, because the voltage at the input of the HUGD-300 will then slightly increase. The resulting unwanted bounces may lead to a loss of stored energy and internal switch overstress. The series resistance should be kept below $0,75 \times V_{th} / P_{out}$.

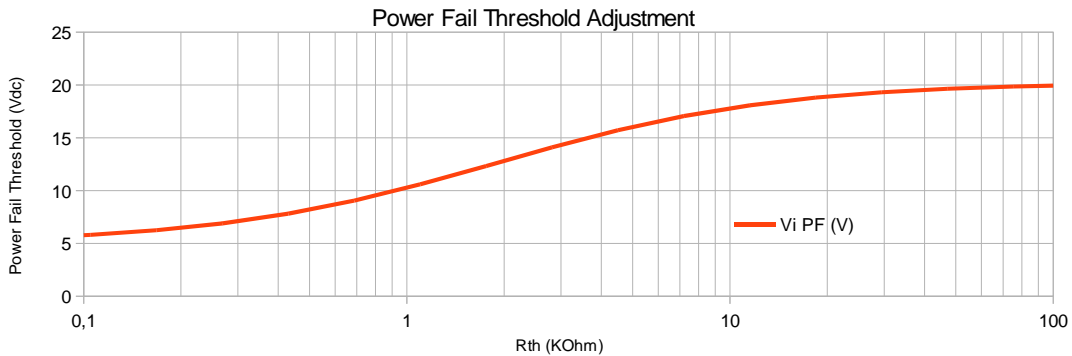

10-4 Hold up Capacitor Charge Voltage Setting and Charging Time : V_{csset}

The HUGD-300 controls the hold-up capacitor charge voltage between 31 VDC to 80 VDC by an external resistance Rcl connected between the Vcset pin and Go pin.

The charging time will be given by the following formula from a capacitor at 0 VDC and is compliant with multiple interruption test given in MIL-HDBK-704E/F condition J :

$$T_{charge} = \frac{2 \times P_{charging}}{C \times V_{cset}^2}$$

where :

- Pcharging : is the charging power
- C : is the hold-up capacitor (in farads)
- Vcset : is the final capacitor voltage set

Shorting Vcset to Go disables the charger.

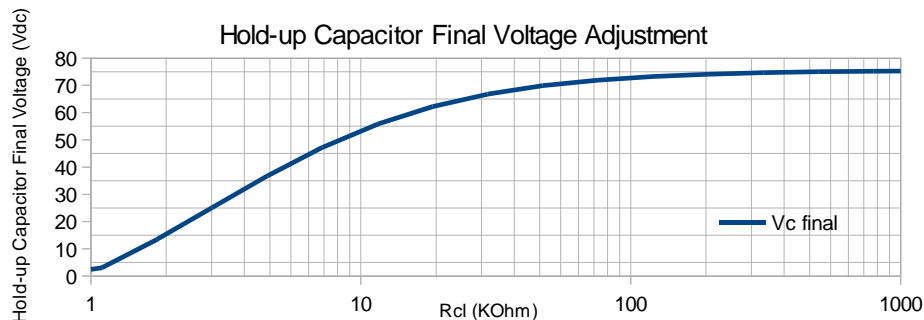

10- Application Notes (continued)

10-5 Power Fail Signal : PF

The «power fail» output signal is activated when the voltage drops below the power fail voltage threshold. The PF signal is an active low open-drain output.

10-6 Capacitor Discharged Signal : CD

The «Capacitor discharged» signal is activated when the voltage at the hold-up capacitor pin reaches 120% of the power fail threshold programmed with the Vth pin to inform the system that the energy storage capacitor voltage is closed to the value which is considered a «power fail» event. It can be used as a last warning before system shut-off. With the Vth pin unconnected, the corresponding value will be 24V, whereas with the Vth pin grounded, the corresponding value will be $V_c = 7.2V$. The CD signal is an open drain active low output.

10-7 Capacitor Charged Signal : CC

The «capacitor charged» signal is activated when the voltage at the capacitor pins reaches 90% of hold up capacitor charge voltage setting Vcset corresponding to an energy stored of about 80% of its full charge. The CC signal is an active low open-drain output.

10-8 Transition Capacitor

To help transitioning the system in the different operating mode, GAIA Converter recommends the use of a transition capacitor. This capacitor is used to maintain output voltage during the HUGD-300 switching from input line to hold up capacitor. A 330 μF electrolytic capacitor is enough for a 300W load, and this value can be reduced for lower loads.

The table below gives the minimum required values versus output power :

Output power (W)	100W	200W	300W
Capacitance value (μF)	TBD	TBD	330

10-9 Typical Schematics

This typical application schematics includes an EMI filter, a LGDS-300 pre-regulator, the hold-up module and an assembly of standard DC/DC converters. Additional details are given in the EMI filters application notes and LGDS-300 datasheet.

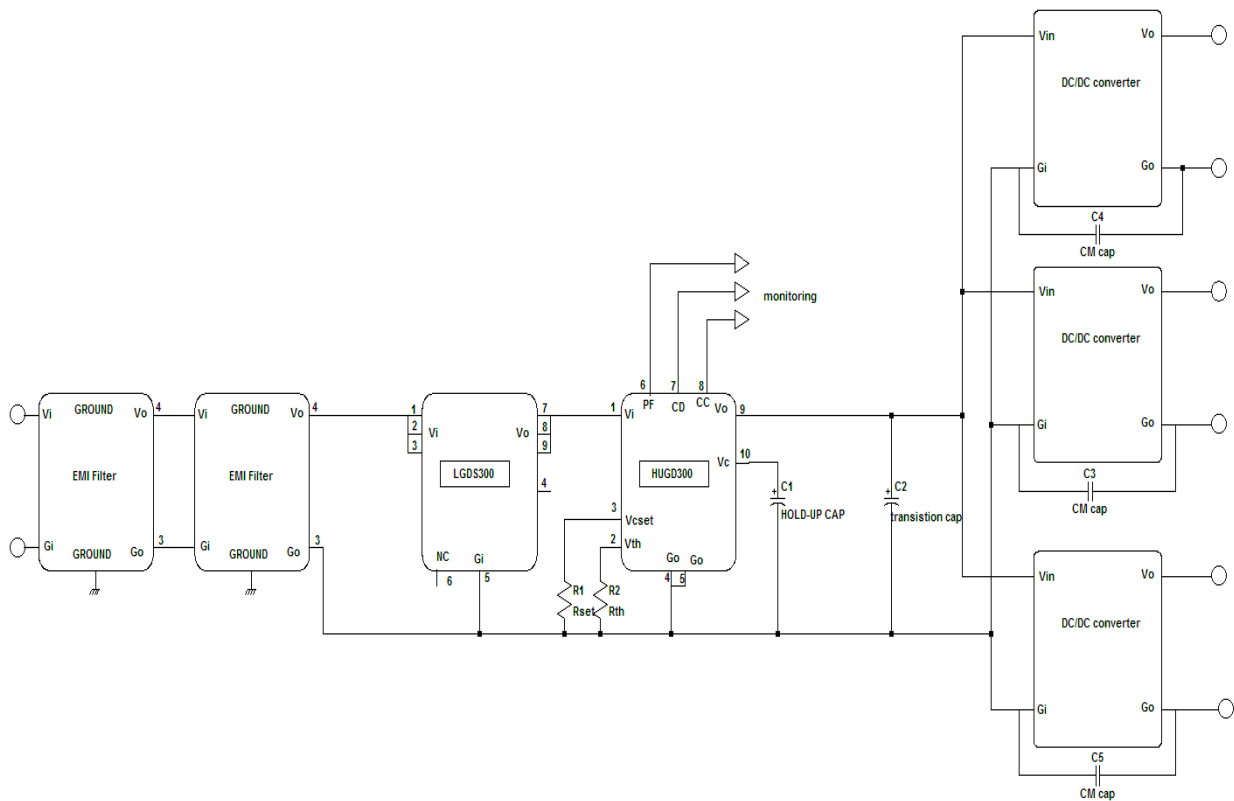

10- Application Notes (continued)

10-10 Timing Diagram

The following diagram describes the HUGD-300 output signals through the different operation modes :

- Input voltage (V_i)
- Output voltage to DC/DC converter (V_o)
- Capacitor voltage (V_c)
- Power Fail signal (PF)
- Capacitor charged signal (CC)
- Capacitor discharge signals (CD)

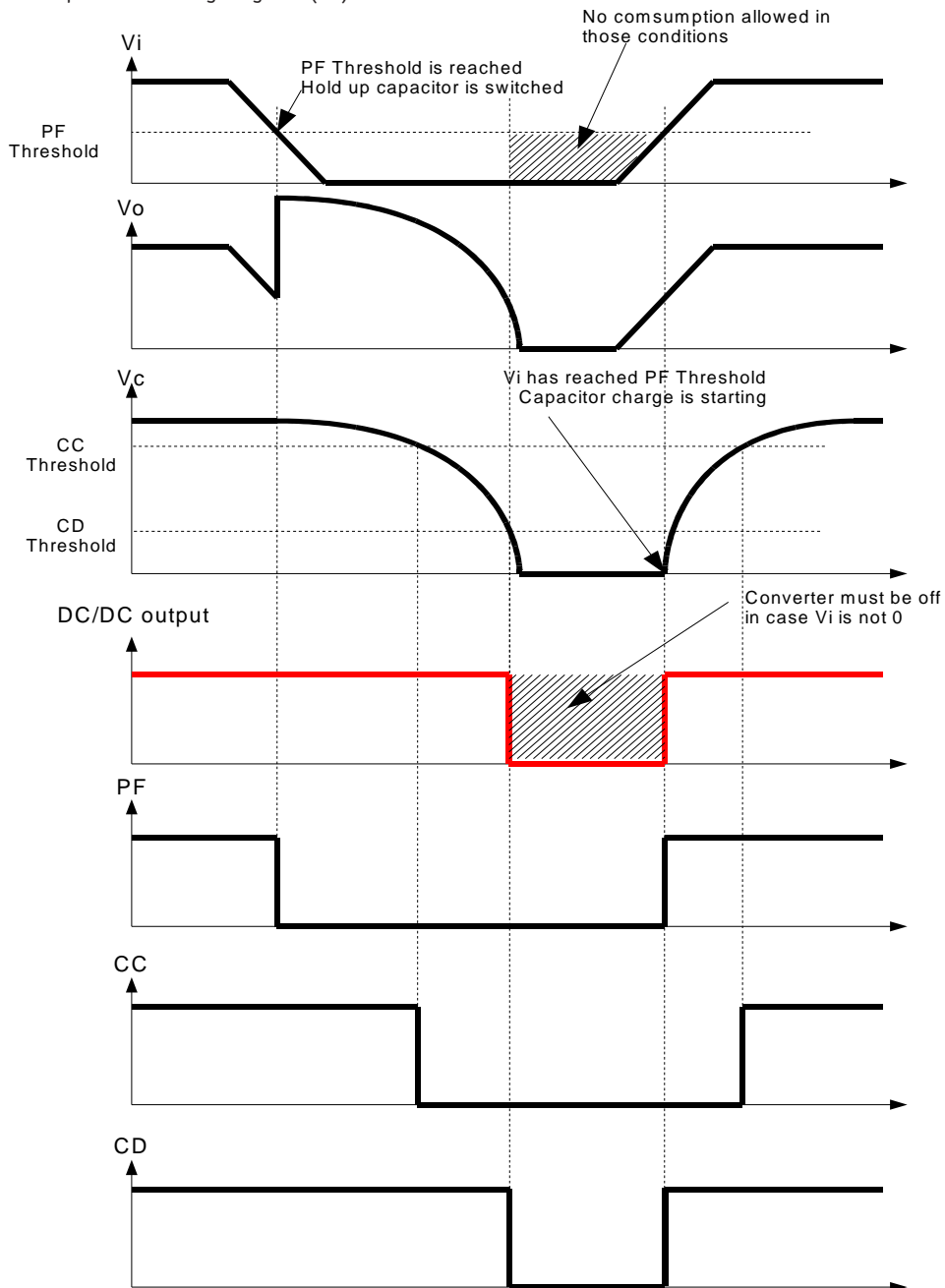

PF, CC, CD Flags are valid for V_o above 6V

11- Dimensions

Dimension are given in mm (inches). Tolerance : +/- 0,2 mm (+/- 0.01 ") unless otherwise indicated.
Weight : 25 grams (0.882 Ozs) max.

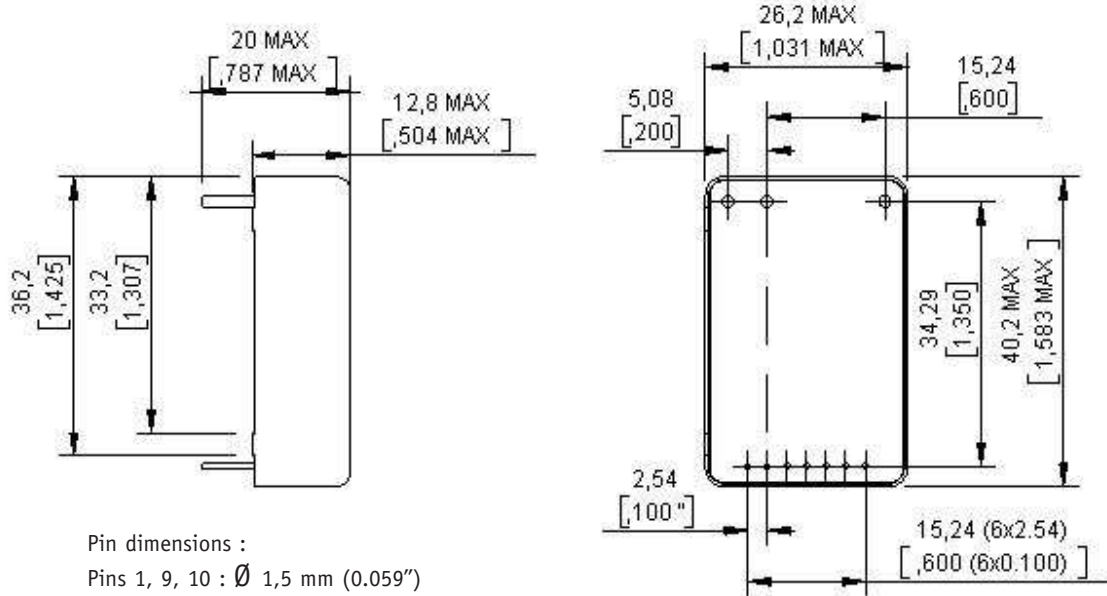

Pin dimensions :
Pins 1, 9, 10 : \varnothing 1,5 mm (0.059")
Pins 2, 3, 4, 5, 6, 7, 8 : \varnothing 0,73 mm (0.029")

12- Materials

Case : Metallic black anodized coating.
Pins : Plated with gold flash over nickel underplate.

13- Product Marking

Upper face : Company logo, location of manufacturing.
Side face : Module reference : HUGD-300.
Date code : year and week of manufacturing, suffix, /option.

14- Connections

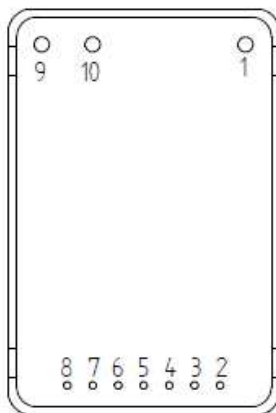

Pin	HUGD-300
1	+ Input (Vi)
2	Power Fail Set (Vth)
3	Capacitor Charge Voltage Set (Vcset)
4	Common (Go)
5	Common (Go)
6	Power Fail Signal (PF)
7	Capacitor discharged signal (CD)
8	Capacitor charged signal (CC)
9	Output (Vo)
10	Voltage Capacitor (Vc)



For more detailed specifications and applications information, contact :

International Headquarters

GAIA Converter - France
ZI de la Morandière
33185 LE HAILLAN - FRANCE
Tel. : + (33)-5-57-92-12-80
Fax : + (33)-5-57-92-12-89

North American Headquarters

GAIA Converter Canada, Inc
4038 Le Corbusier Blvd
LAVAL, QUEBEC - CANADA H7L 5R2
Tel. : (514)-333-3169
Fax : (514)-333-4519

Represented by :